

9.1 High-power tubular heating element Ø 8.4

APPLICATION

- **Water** in kettles, boilers, heat exchangers, rinsing and degreasing baths, double jackets for indirect heating, etc.
- **Oil** for hardening-, hydraulic- or lubrication systems, in gear boxes, oil tanks, etc.
- **Other fluids** like tar, paraffin, tetrachloroethylene, diphyl, glycerin, phosphat ester, melting of tin or lead
- **Solid media** like heating plates, machine parts, rollers, tanks, etc. (built-in or pressing-on), aluminium parts (cast-in)
- **Air** in air heaters or circulating air ovens, in heating cabinets and drying furnaces as radiant heating elements
- Further applications please see catalogue page 9.6



DESIGN

- Heating element consists of a coiled heating wire with welded-on connection bolts, centrally embedded in highly compressed insulating material, protected by a bendable metal tube
- the tube ends are sealed by ceramically lock bushings.

TECHNICAL ADVANTAGES

- High degree of operational reliability, dielectric strength, protection against contact and humidity, resistant against external influences and high temperatures
- good heat transmission and heat conductivity
- easy malleable, stable and vibration resistant
- long life expectancy

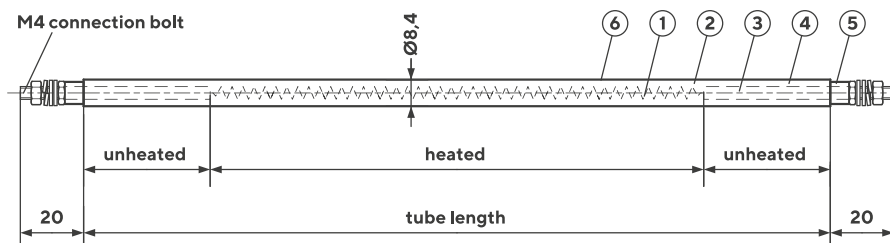

1. Heating wire NiCr 30 20 or NiCr 80 20
2. Insulating made of magnesium oxid with high electrical insulation capacity and good thermal conductivity
3. Connection bolts M4 made of stainless-steel are part of the unheated zone of the tubular heating element.

Following length of connection bolts are available from stock:

30 mm	100 mm	200 mm	300 mm
50 mm	120 mm	220 mm	weiter alle
65 mm	150 mm	250 mm	50 mm to
80 mm	175 mm	270 mm	850 mm

4. Tube ends are sealed with silicone (up to 180°C) or synthetic resin (up to 130°C)
5. Ceramic lock bushing, white or colourfully
6. Tube jacket, depending on the intended use (see page 9.3)

MATERIAL-NO.	MATERIAL	SHORT NAME	CHARACTERISTICS
1.0108	steel	ST 34-2	max. surface temp. 400 °C
1.4541 (AISI 321)	chrome-nickel steel	X6 CrNiTi 18 10	max. surface temp. 750 °C
1.4571 (AISI 316Ti)	chrome-nickel steel	X6 CrNiMoTi 17 12 2	corrosion resistance
1.4828 (AISI 309)	chrome-nickel steel	X15 CrNiSi 20 2	max. surface temp. 850 °C
1.4876 (alloy 800)	chrome-nickel steel	X10 NiCrAlTi	corrosion and temp. resistance
2.4858 (alloy 825)	special material	NiCr 21 Mo	high degree of corrosion resistance
3.7035	titanium	Ti Gr. 2	high degree of corrosion resistance

9.2 High-power tubular heating element Ø 8.4

TESTING

- tested and certified according to VDE
- routine testing according to DIN 60335-1
- marks approval, certificate no. 40057393



TOLERANCES

- diameter Ø 8.4 mm +/- 0.1 mm
- length +/- 2%, tighter tolerances on request
- power +5% / -10%, tighter tolerances on request

STAMP

- Month, HELIOS, Year, Voltage and Power

WEIGHT

- depends on tube jacket material, approx. 240 – 270 g/m

MANUFACTURING LIMITS

min. length	300 mm	
max. length	6300 mm	steel, stainless-steel 1.4876 (alloy 800)
max. length	7000 mm	stainless-steel mat.-no. 1.4541 (AISI 321), 1.4571 (AISI 316Ti), 1.4828 (AISI 309), 2.4858 (alloy 825)
max. voltage	690 V	
min. resistance	3 Ω/m, heated length	
max. resistance	500 Ω/m, heated length	
max. power	4.000 W at 230 V and	max. 4 m heated length
max. power	3.000 W at 230 V and	max. 5 m heated length
max. power	2.000 W at 230 V and	max. 6 m heated length
min. power	100 W at 230 V and	min. 1 m heated length
min. power	200 W at 230 V and	min. 0,5 m heated length
min. power	400 W at 230 V and	min. 0,25 m heated length



SPECIAL DESIGN

unheated sections

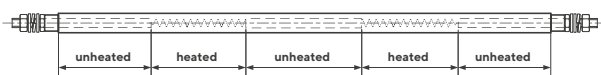

low heated sections

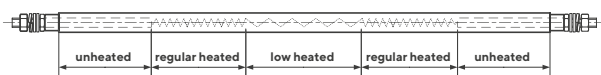

more heated sections

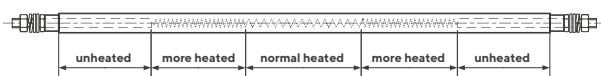

different length of unheated zones from the end of the tube

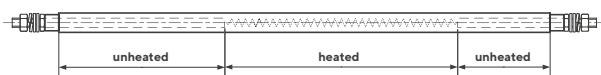

finned-tube heating element Ø 28 mm, see page 9.11 and 9.12

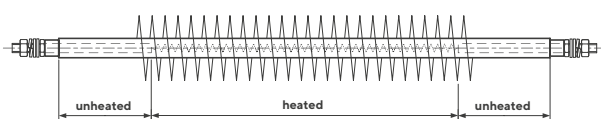

9.3 High-power tubular heating element Ø 8.4

Chart for determination of maximum surface load and tube material for different applications.

MEDIUM / APPLICATION	MAX. MEDIUM TEMPERATURE (°C)	MAX. SURFACE LOAD (WATT/CM²)	HEATING ELEMENT TUBE-JACKET MATERIAL						
			STEEL	AISI 321 (1.4541)	AISI 316TI (1.4571)	AISI 309 (1.4828)	ALLOY 800 (1.4876)	ALLOY 825 (2.4858)	TITAN
WATER									
Tap water (soft)	60	5,0 to 8,0						x	
Tap water (hard)	60	3,0 to 5,0						x	
Water (circulation)	100	10,0			x			x	
Water (deionized)	100	10,0			x				
Water (vaporization)	100	5,0			x			x	
AQUEROUS FLUIDS									
Caustics soda	100	2,0						x	x
Bases (aqueous)	100	4,0	x		x			x	
Suds (moved)	100	8,0			x			x	
Acids (aqueous)	100	2,0			x			x	
Milk	50	1,0			x				
Seawater	100	5,0						x	x
OIL									
Hydraulic oil	40	1,5	x						
Lubricating oil	40	1,0	x						
Thermal oil	300	5,0	x						
Heating oil EL	2	4,0	x						
Heavy fuel oil	100	1,5	x						
OTHER FLUIDS									
Lead bath	500	4,0		x	x				
Diphyl	350	1,5	x		x				
Frying oil	200	4,0			x				
Glycerin	110	3,0	x						
Carbon dioxide (fluid)	20	3,0	x						
Phosphate ester	40	1,0	x						
Molten salt	400	2,0			x				
Lubricating grease	40	0,5	x						
Tar	150	1,0	x	x					
Water glycol mixture	130	3,0			x				
Wax	60	1,0	x						
SOLID MEDIA									
Aluminium (cast-in)	300	8,0	x	x					
Charcoal (to ignite)	600	3,5					x		
Metal (pressed-on)	300	2,0 to 4,0	x	x		x			
Metal (pressed-in groove)	300	6,0				x			
Sawdust (to ignite)	600	3,5					x		
Sand	200	1,5				x			
Sawdust (to ignite)	600	2,0		x		x			
Roller	300	2,5							
AIR									
Air (stationary)	750	diagram 3		x		x			
Air (moved)	750	diagram 4 to 6		x		x			
Radiant heating element		3 to 5				x			
Grill (BBQ) heating element		4,0				x			
Defrost heating element		1,0		x					

9.4 High-power tubular heating element Ø 8.4

DIAGRAM 1: AIR SPEED 0 M/S, STATIONARY AIR

Determination of the surface temperature of the tube jacket depending on the surface load and air temperature at stationary air.

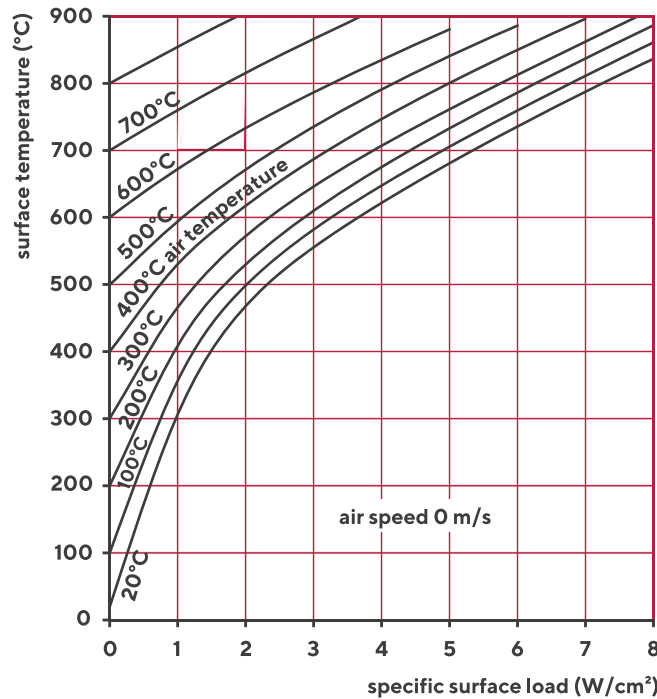
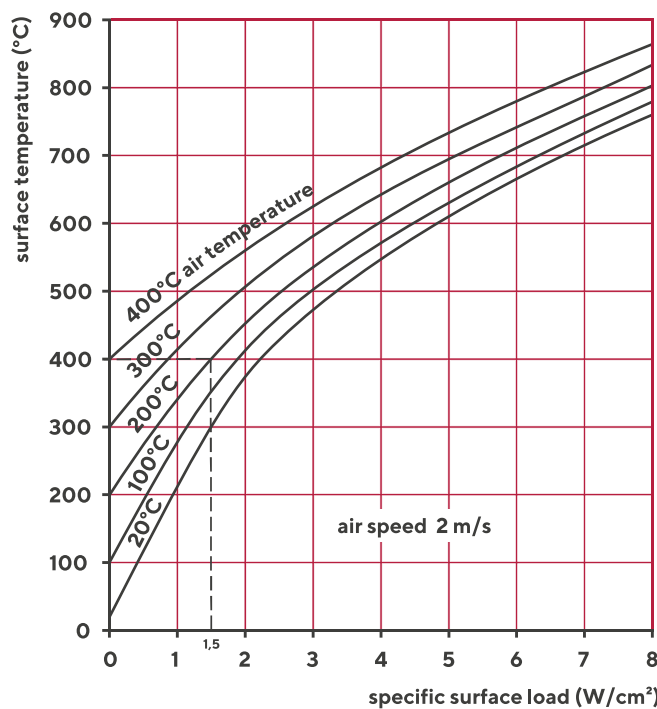

DIAGRAM 2: AIR SPEED 2 M/S, STATIONARY AIR

Determination of the surface temperature of the tube jacket depending on the surface load and air temperature at stationary air.



9.5 High-power tubular heating element Ø 8.4

DIAGRAM 3: AIR SPEED 5 M/S, STATIONARY AIR

Determination of the surface temperature of the tube jacket depending on the surface load and air temperature at stationary air.

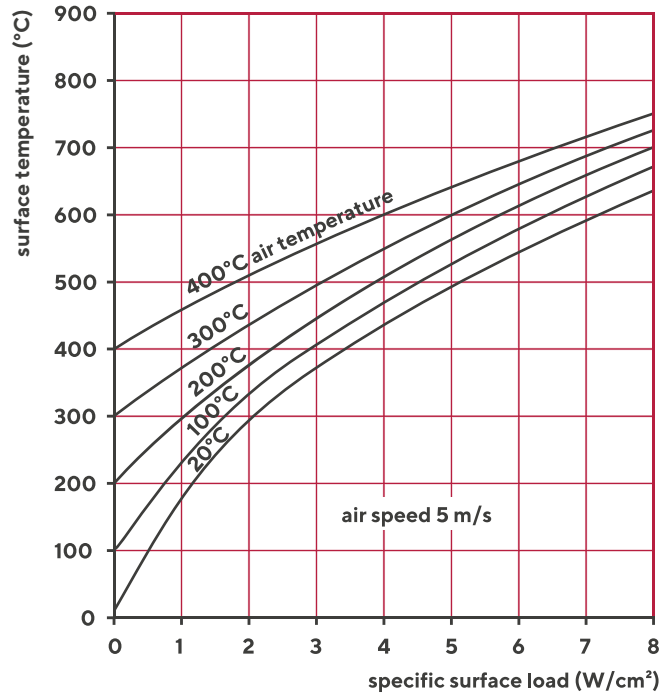
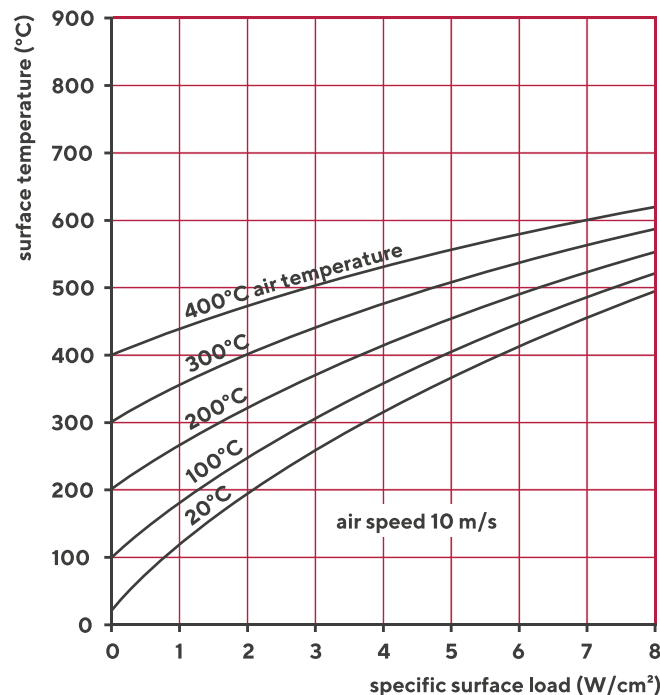

DIAGRAM 4: AIR SPEED 10 M/S, STATIONARY AIR

Determination of the surface temperature of the tube jacket depending on the surface load and air temperature at stationary air.



9.6 High-power tubular heating element Ø 8.4

CONNECTION OPTIONS

- Connection bolts M 4 made of stainless steel, standard
- Flat plug acc. to DIN 46244, plug width 6.3 mm
- Nickel wire tack welded, up to 600 °C ambient air temperature
 - 1 mm²
 - 2 mm²
- Nickel wire glass fibre insulated nickel wire, tack welded up to 400 °C ambient air temperature
 - 1,5 mm²
 - 2,5 mm²
 - 4,0 mm²
- Nickel wire pearl insulated nickel wire, tack welded, up to 600 °C ambient air temperature
 - 1 mm²
 - 2 mm²
- Connection waterproof
- heat-shrink tubing additional protection for rough environmental conditions
- earth protection copper wire 1.5 mm² with green/yellow plastic insulation

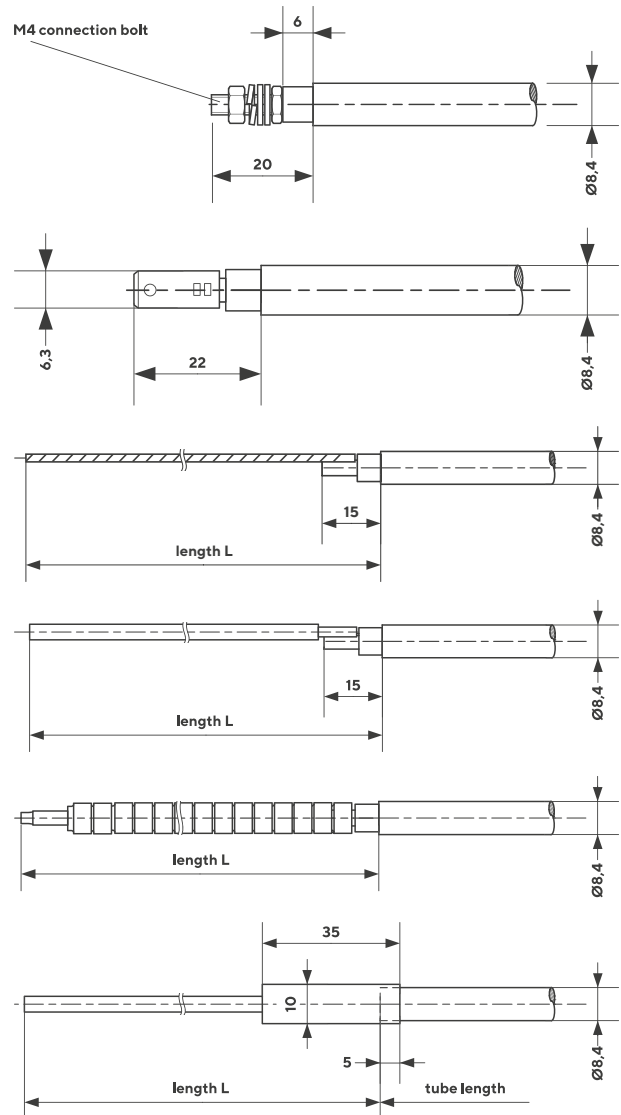
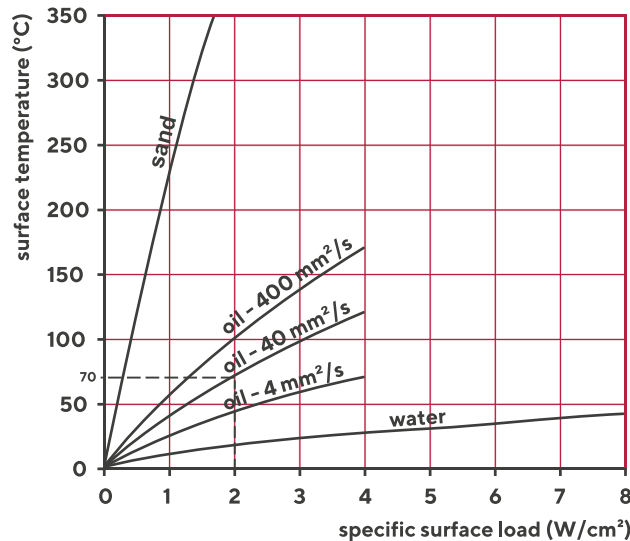

DIAGRAM 5

Determination of the temperature difference between tube jacket and medium as a function of the surface load of the heating element for different stationary media.



9.7 High-power tubular heating element Ø 8.4

Mounting and installation

SCREW-NIPPELS

- at the tube end, hardsoldering (brazing), with nut and gasket

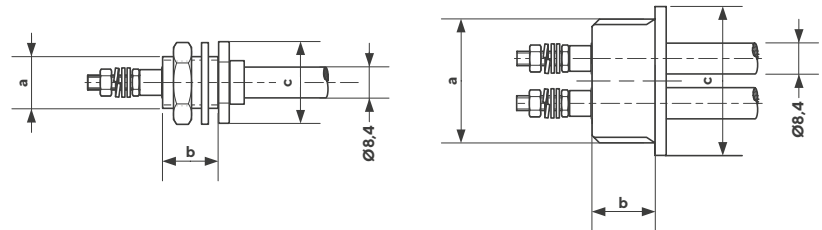

TECHNICAL DATA

a THREAD	b LENGTH (APPROX. MM)	c COLLAR (APPROX. MM)	MATERIAL	ARTICLE NO.
for 1 tube end				
M 14 x 1,5	10	SW 19	1.4305	09070011
M 14 x 1,5	15	SW 19	brass	09070021
M 14 x 1,5	15	SW 19	steel	09070031
M 14 x 1,5	15	SW 19	1.4305	09070041
M 14 x 1,5	15	SW 19	1.4571	09070051
M 14 x 1,5	25	SW 19	brass	09070061
M 14 x 1,5	25	SW 19	steel	09070071
M 14 x 1,5	25	SW 19	1.4305	09070081
M 14 x 1,5	25	SW 19	1.4571	09070091
M 14 x 1,5	40	SW 19	brass	09070111
M 14 x 1,5	40	SW 19	1.4571	09070121
for 2 tube ends				
M 26 x 1,5	11	Ø 32	brass	09080011
M 26 x 1,5	21	Ø 32	brass	09080021
M 26 x 2,0	23	Ø 32	1.4571	09080041
G 1	17	Ø 40	brass	09080061
for 4 tube ends				
G 1	17	Ø 40	brass	09080101

SCREW-CAP

- protection type IP 65, with cable gland and gasket

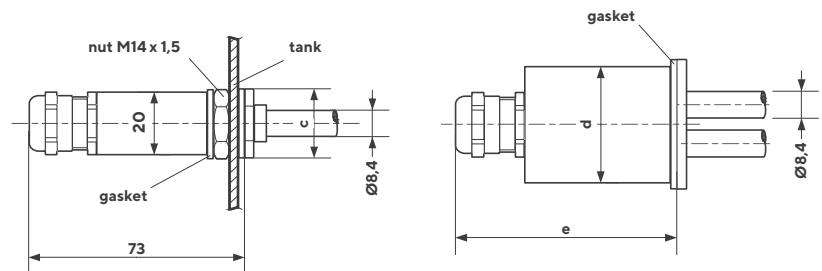

TECHNICAL DATA

a THREAD	b LENGTH (APPROX. MM)	c COLLAR (APPROX. MM)	MATERIAL	ARTICLE NO.
M 14 x 1,5	73	20	brass	09081011
M 26 x 1,5	50	29	brass	09081021
M 26 x 1,5	50	29	synthetic material	09081031
G 1	60	36	brass	09081061
G 1	60	36	synthetic material	09081071

9.8 High-power tubular heating element $\varnothing 8.4$

SHAPING

- Tubular heating elements can be formed when cold
- When bending, make sure that the unheated zone ends at least 10 mm in front of the bend or 10 mm behind the bend
- Bends below radius $R = 50$ mm can only be bent with using a bending tool and profiled bending rolls
- Smallest bending radius is $R = 8.5$ mm
- This corresponds to a bending roll diameter of 17 mm
- For 180° bends, the bending radius can be reduced to $R = 2.5$ mm, by subsequently compressing the tube legs
- for special material mat.-no 2.4858 (alloy 825) and titanium, the smallest bending radius is $R = 12.5$ mm
- bendings rolls $\varnothing 17, 20, 25, 30, 35, 40, 45, 50, 60, 70, 75, 80, 90$ and 100 mm
- The distance between two bends should be at least 15 mm

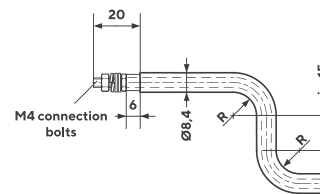
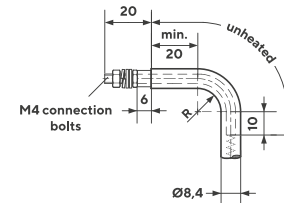
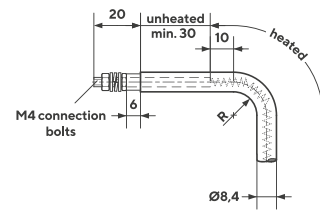

SHAPING EXAMPLES

